

15.05.2013

“

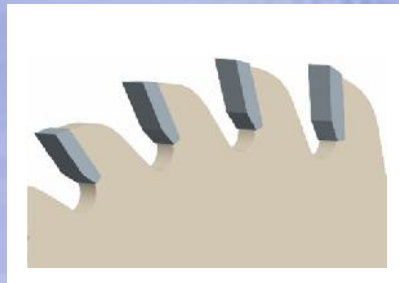





FZ

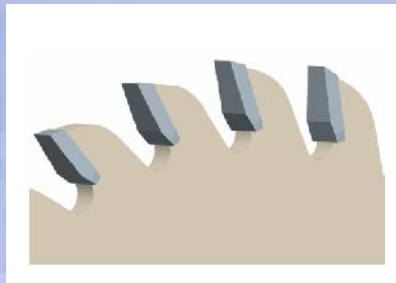

KONFZ

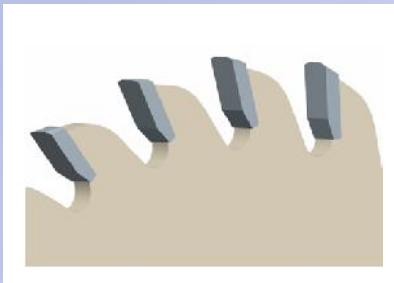

FZ/FA

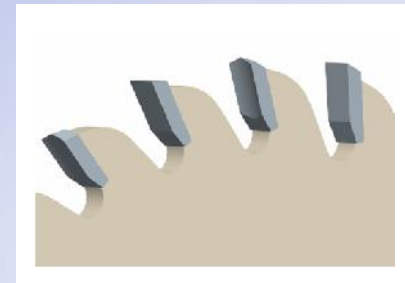

FZ/HZ



WZ

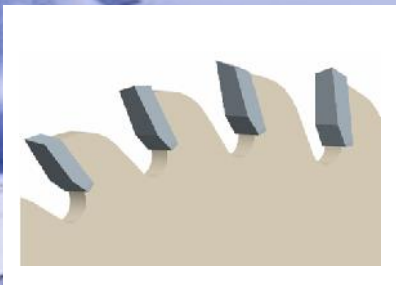

KONWZ

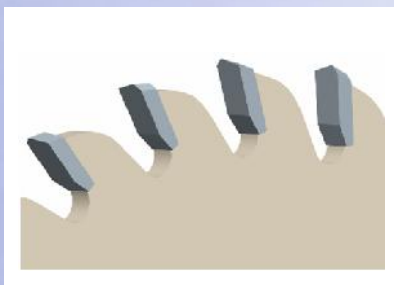

WZ/FA



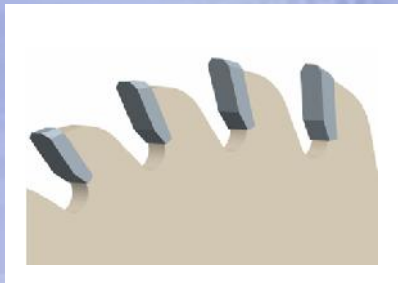

TR

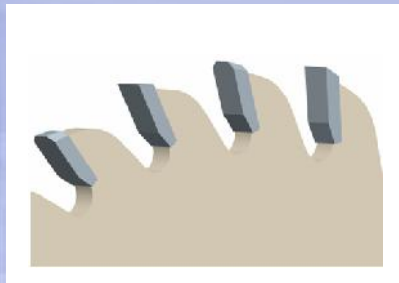

FZ/TR

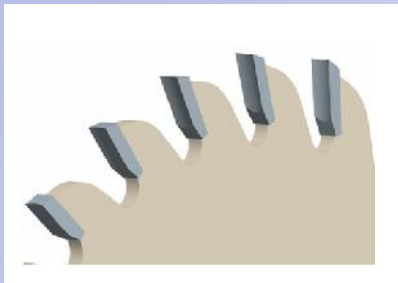

HZ

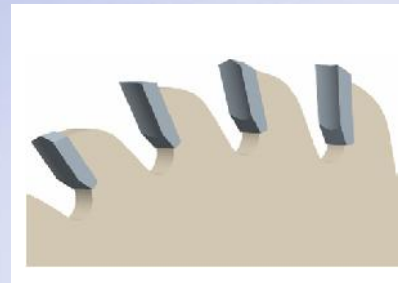

DZ/HZ



HZ/FA



ES

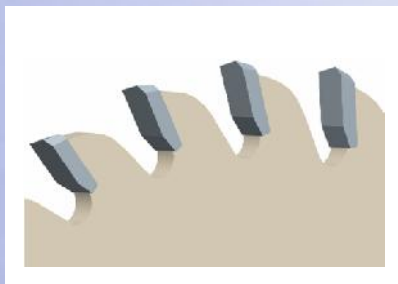

ES/FA



GZ



○

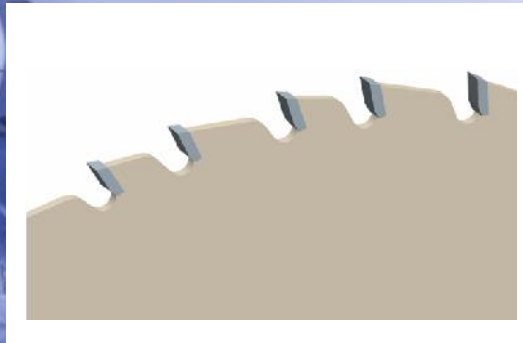
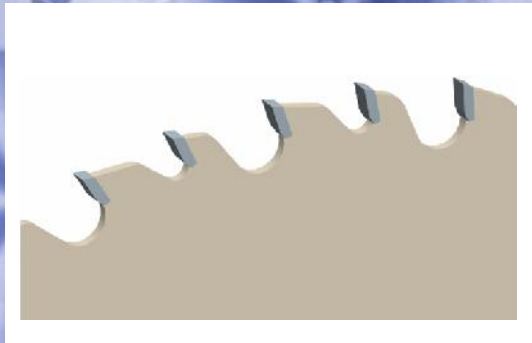
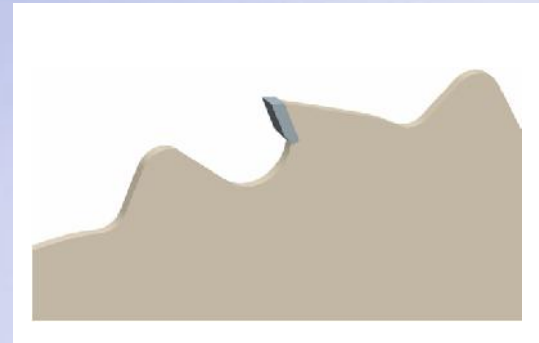
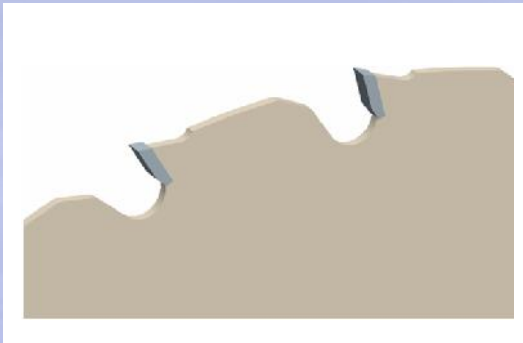
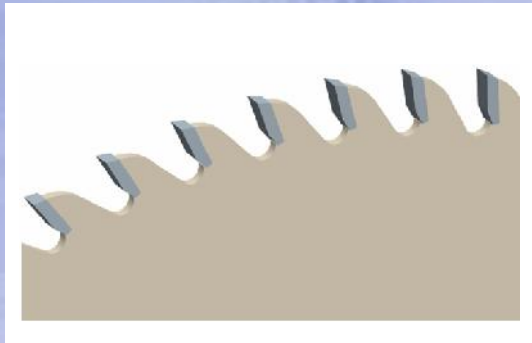

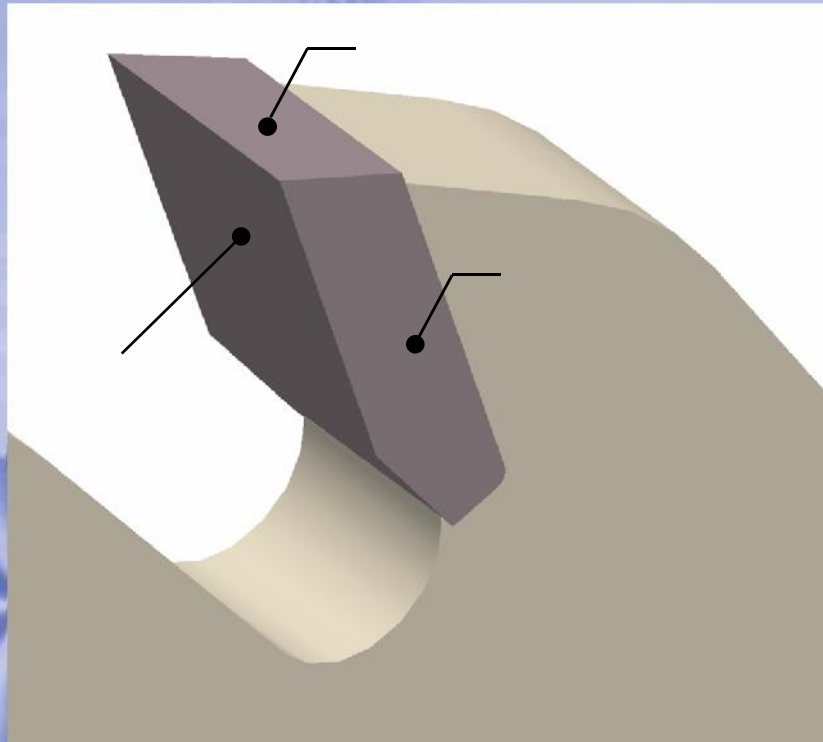

- : Rz 1
- : Rz 1
- : Rz 2.5
- : Rz 8



max.
0.012

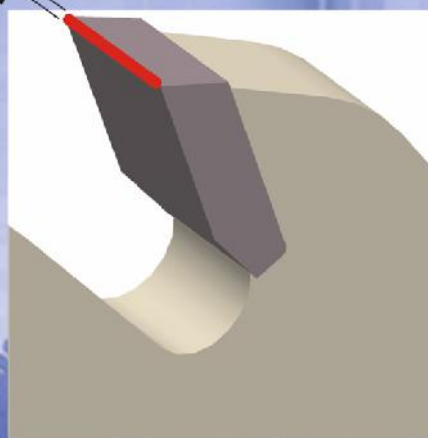

R_t 0.003

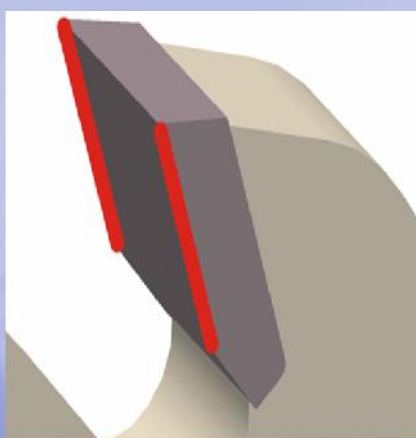

max.
0.03

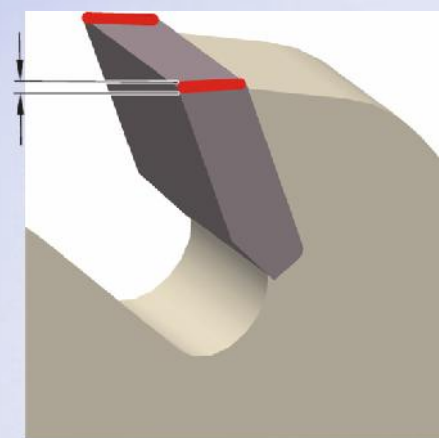

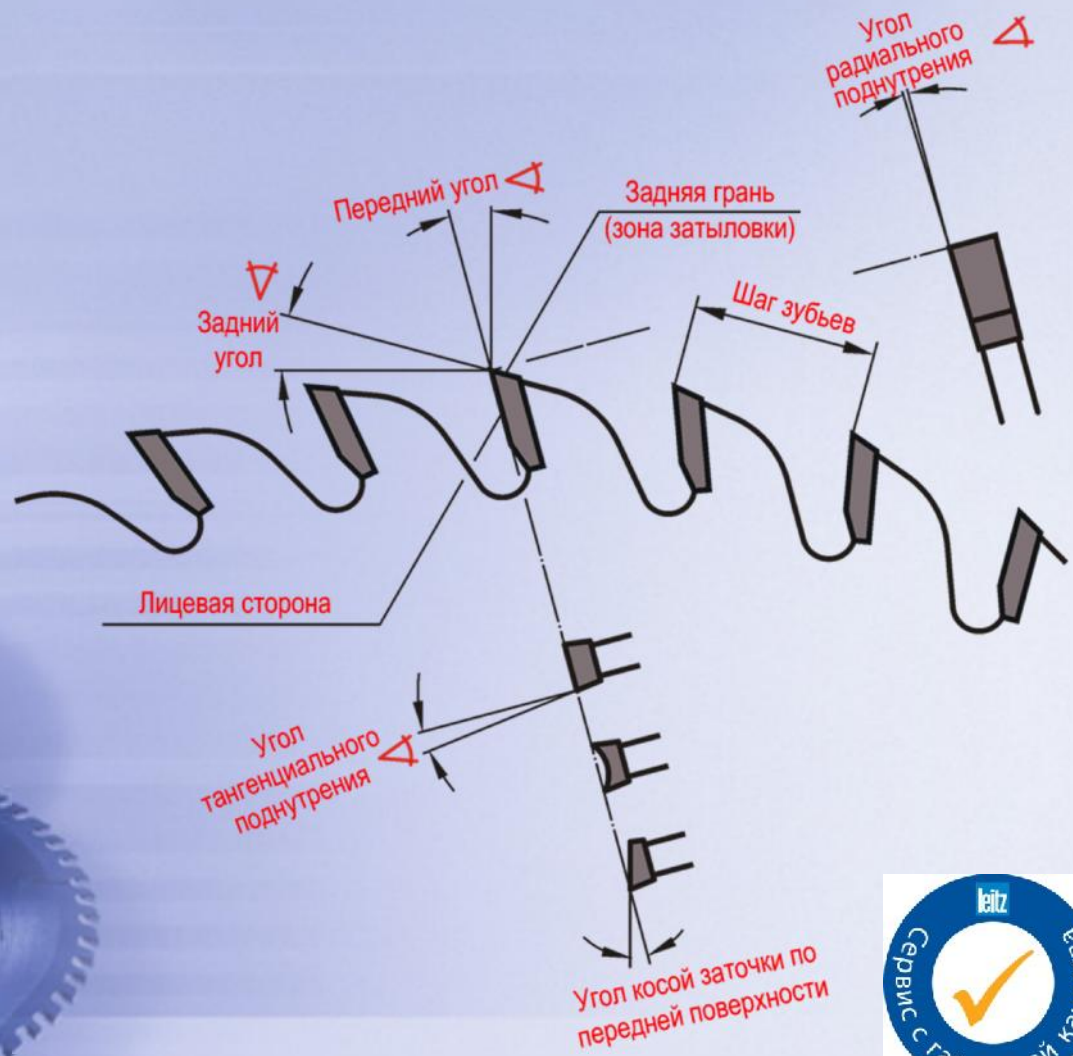
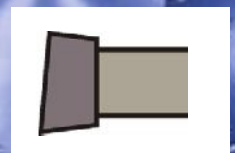
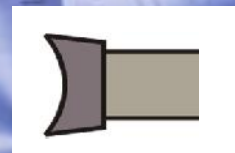
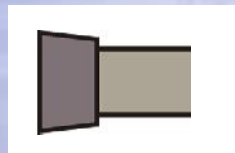

WZ

$\pm 0,1 B$

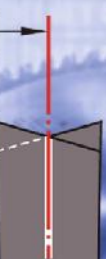

DZ

$\pm 0,1 B$



TR

$\pm 0,1 B$

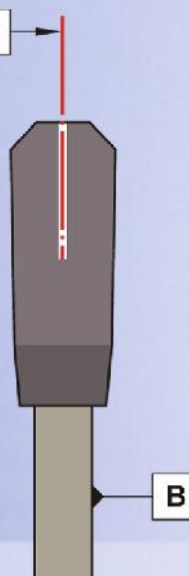

HZ

$\pm 0,1 B$

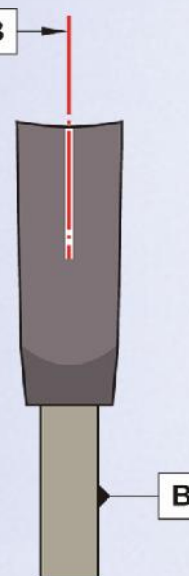

DZ / FZ

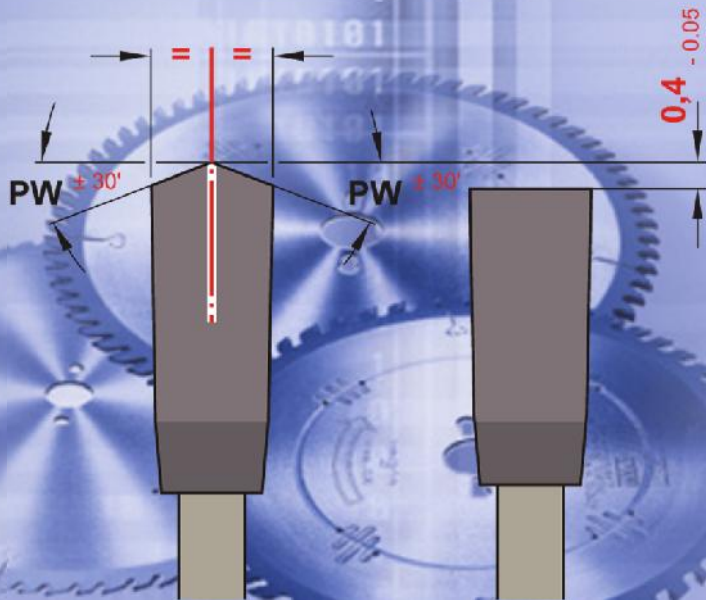

DZ / HZ

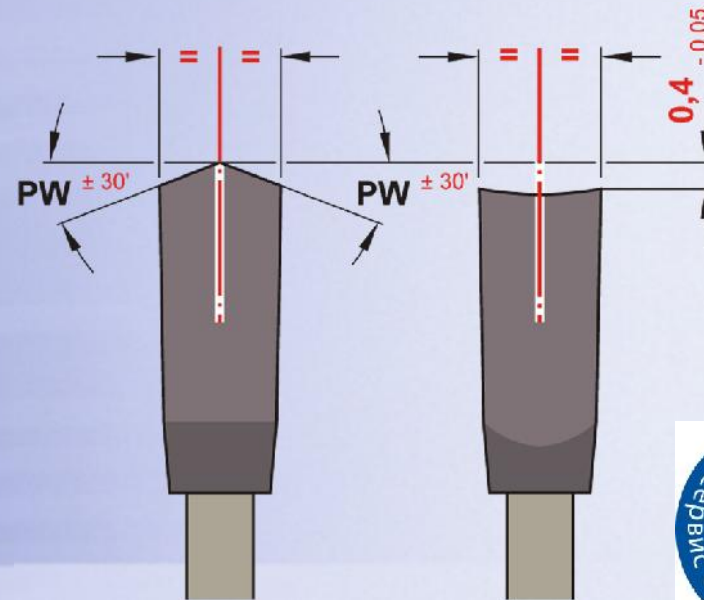

FZ / TR

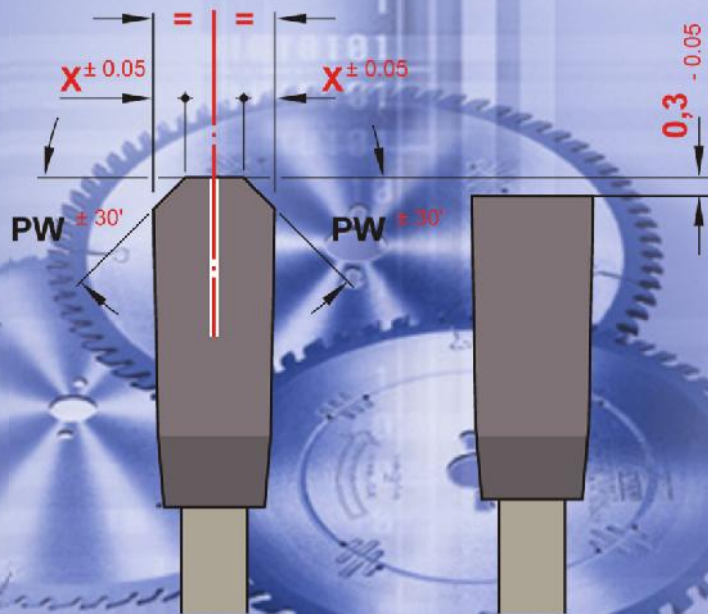

TR / TR

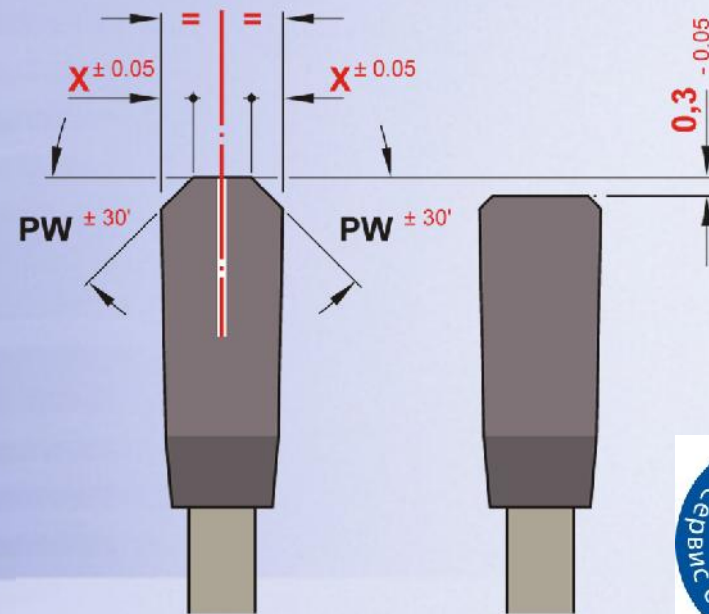

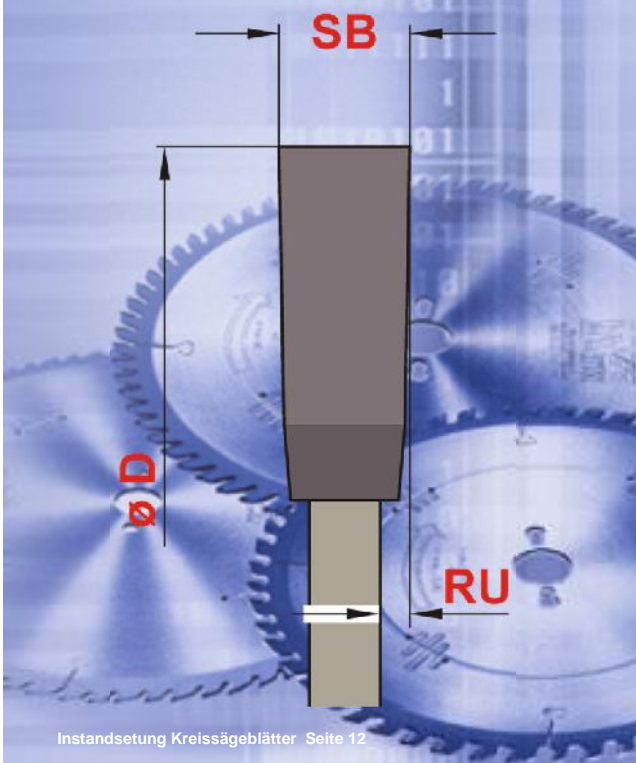

	D	SB RU < 0,4	SB RU > 0,4
D > 200	± 0,5	± 0,5	+ 0 - 0,1
200 < D > 400	+ 1 - 0,5		
400 < D > 500	- 0,5	± 0,1	+ 0 - 0,2
500 < D > 1000	+ 2 - 1		
1000 < D > 1200	± 2		



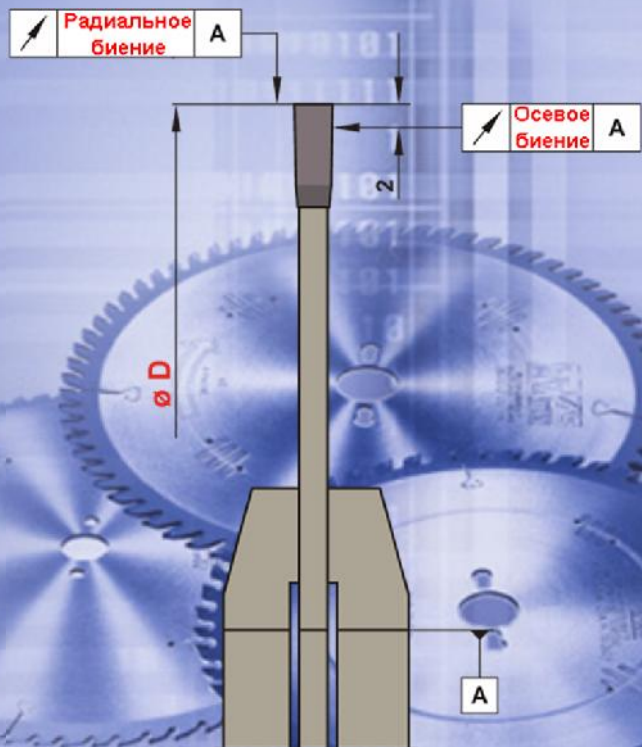

Диапазон диаметров	Радиальное биение	Осевое биение	Градации от зуба к зубу	
			Радиальное биение	Осевое биение
D ● 305	0,1	0,15	1/2 от допустимого радиального биения	1/2 от допустимого осевого биения
305 < D ● 500	0,1	0,2		
500 < D ● 750	0,2	0,25		
750 < D ● 1000	0,2	0,3		
1000 < D ● 1200	0,2	0,35		





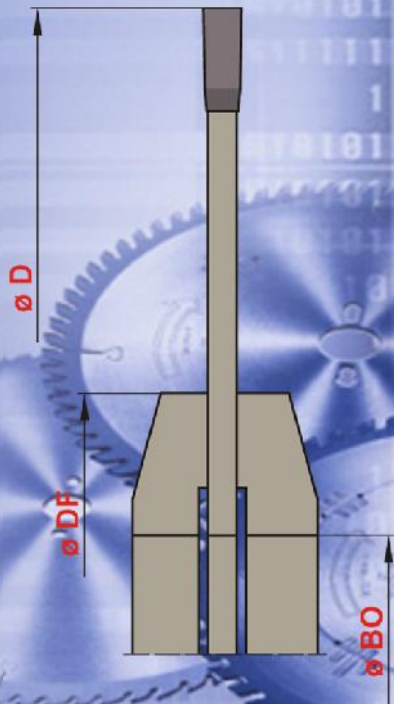

	... 20	20 ... 30	30 ... 40	40 ... 60	60 ... 80	80 ... 100	100 ... 120	120 ... 140	140 ... 150
D \bullet 100	60		(80)						
100 < D \bullet 140	60	80		(100)					
140 < D \bullet 190	80			100	(120)				
190 < D \bullet 210	80			100	120	(140)			
210 < D \bullet 250	100				140		160		
250 < D \bullet 300	120				140		160	(180)	
300 < D \bullet 400	120				140		160	180	200
400 < D \bullet 450	140				160		180	200	
450 < D \bullet 560	140			180			200		
560 < D \bullet 630	160			180		200			
630 < D \bullet 800	200						250		
800 < D \bullet 1000	250								
1000 < D \bullet 1200	300								

ТАВПАМИ ПЛАСТИПАМИ

ну углов

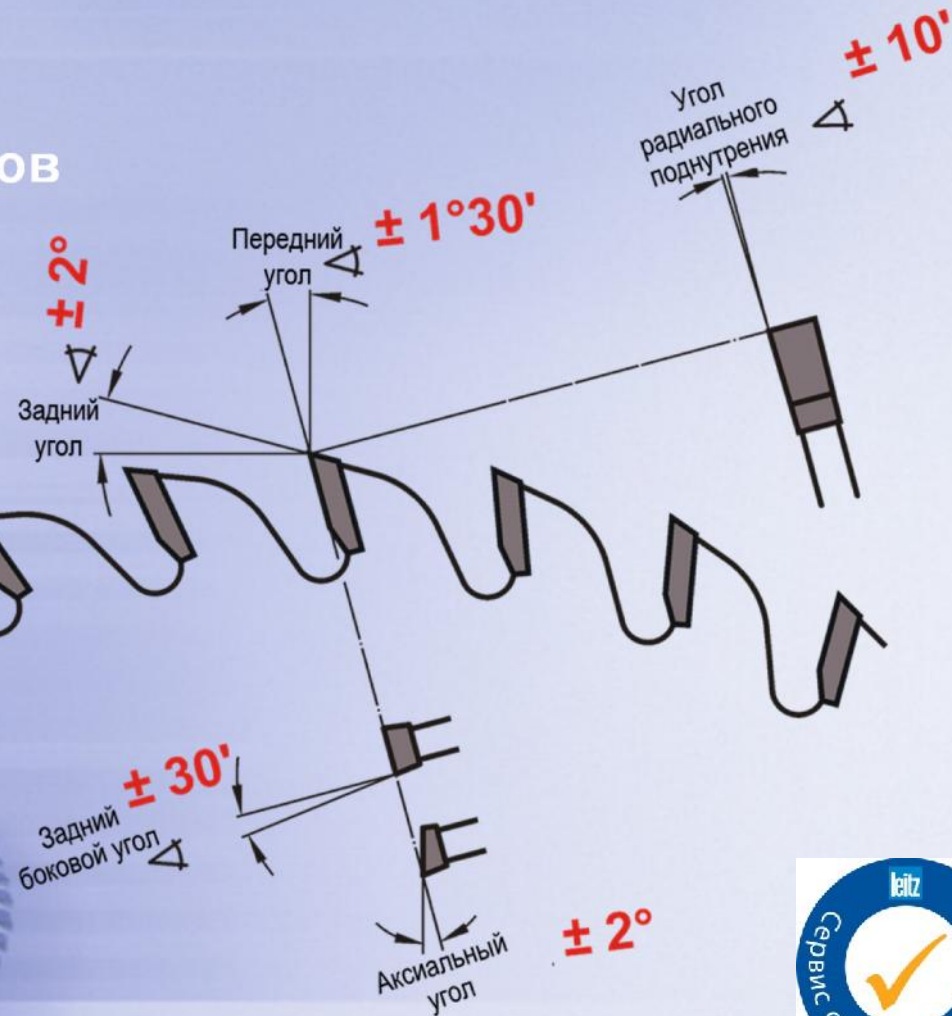

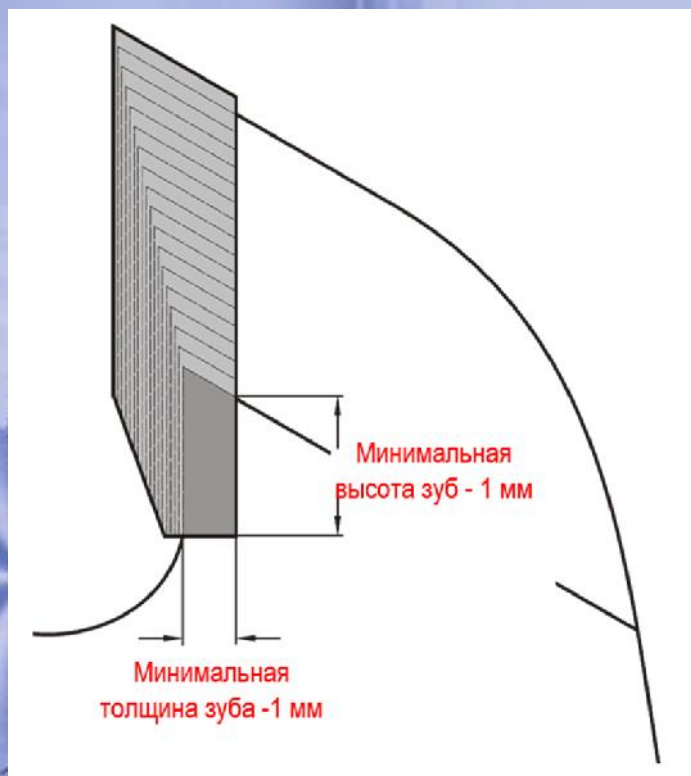

:
 : 0.05-0.08
 : 0.3
 : 65°
 : 0.37
 :

1

1



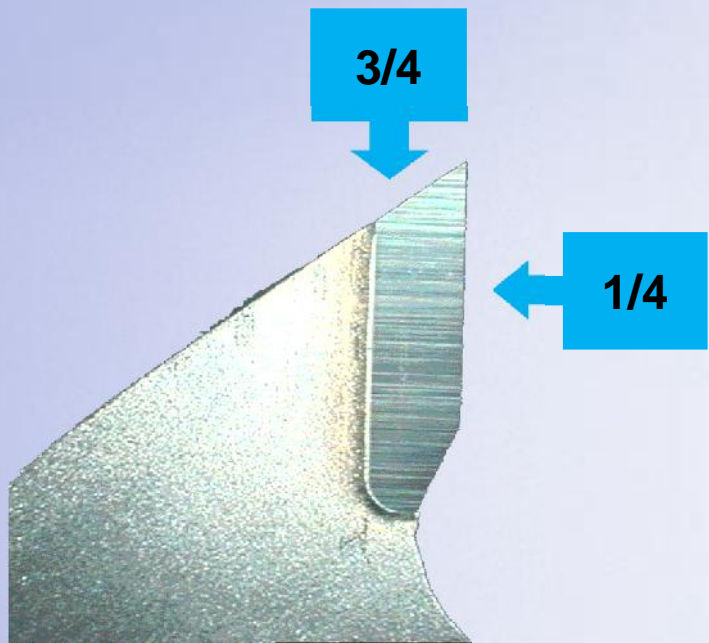
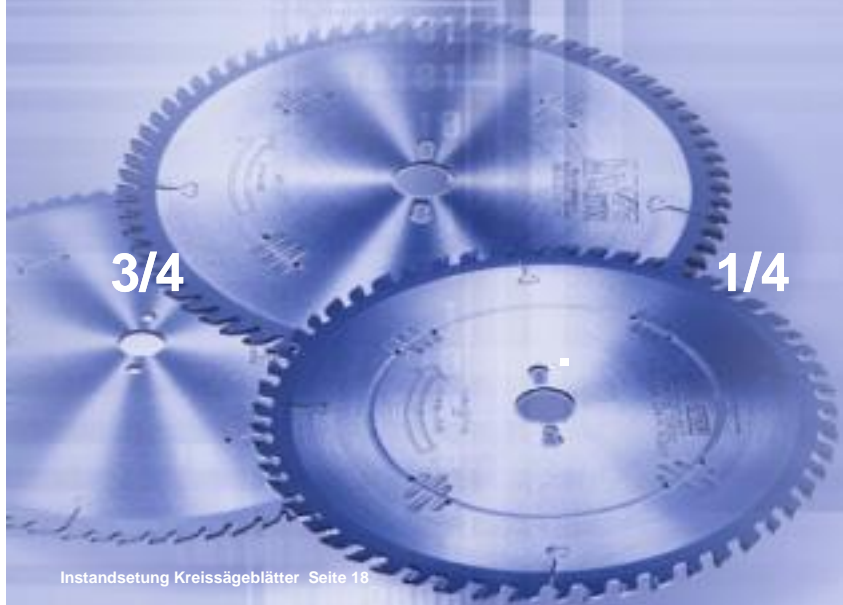

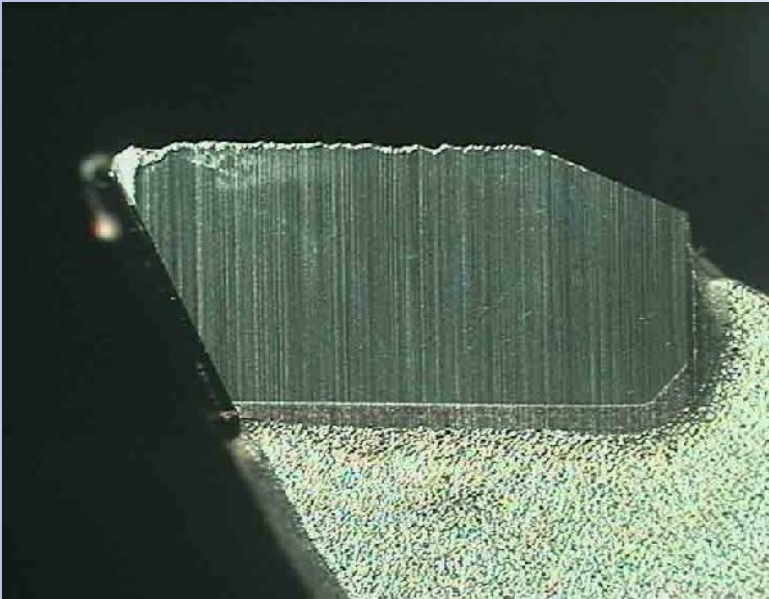

1/2

ProFix Kesselbach 04.04 z0

1/2

1/2

1/2

:

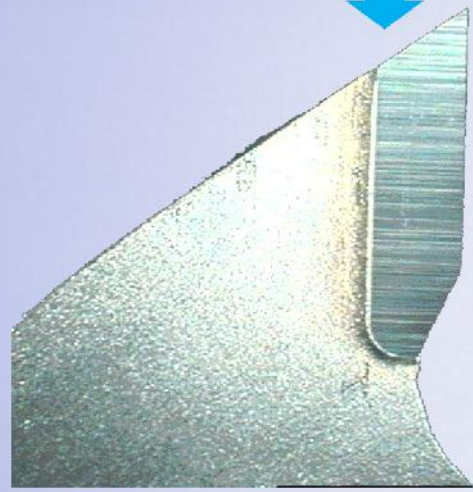

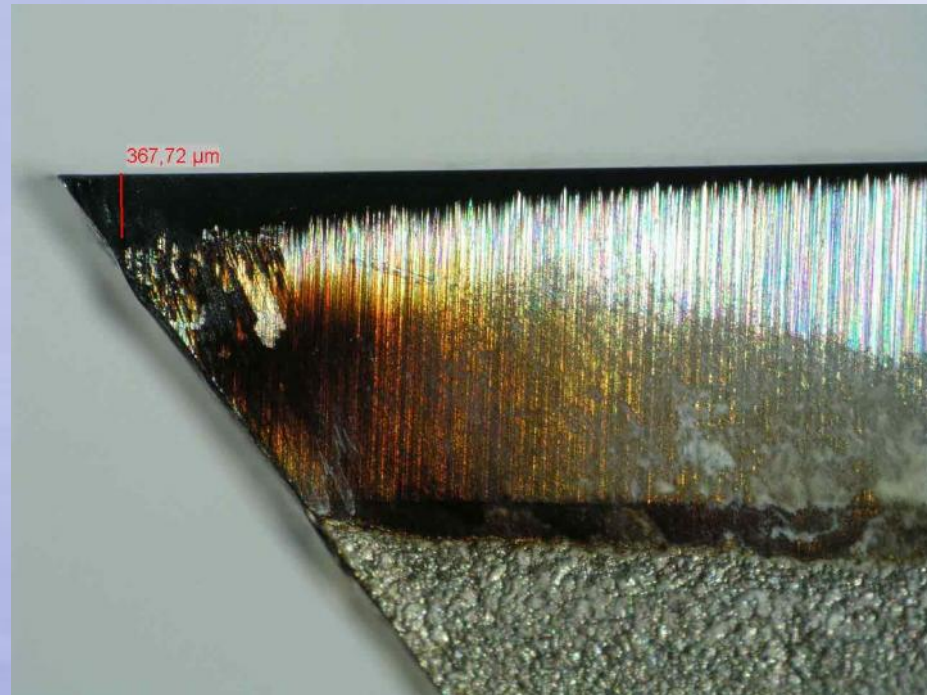

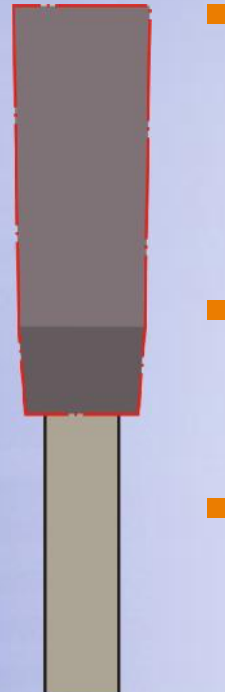

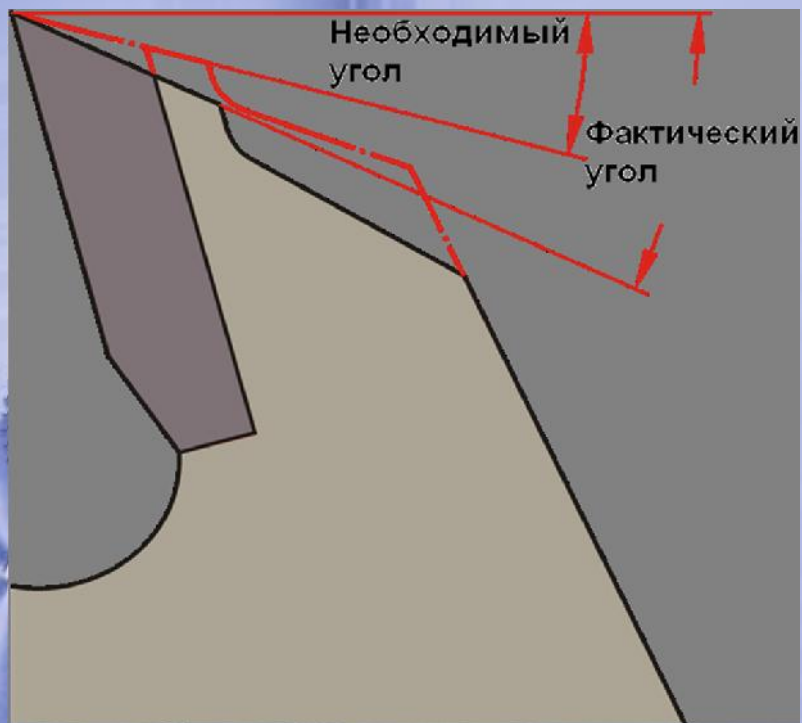

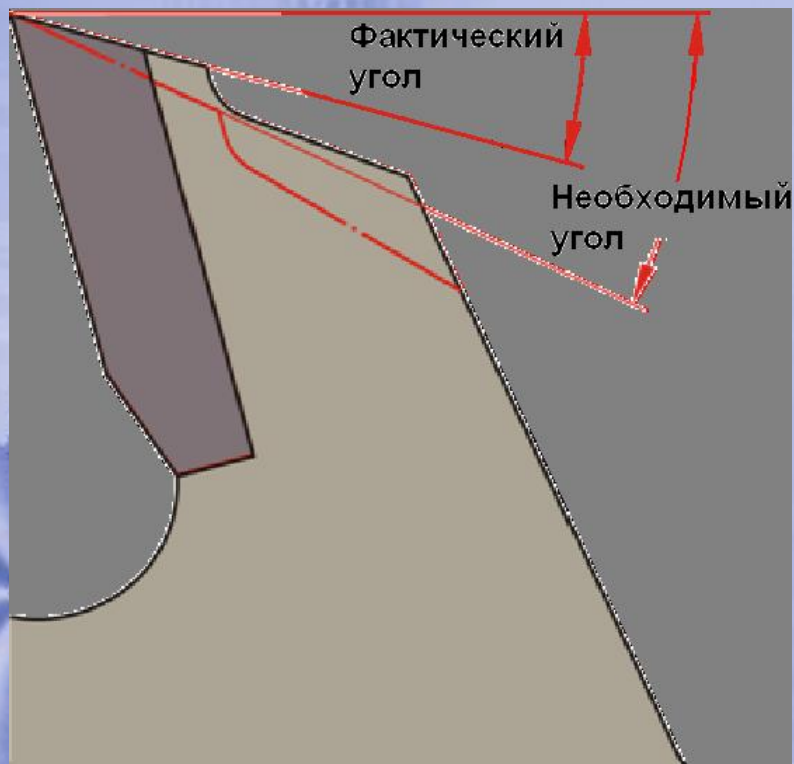

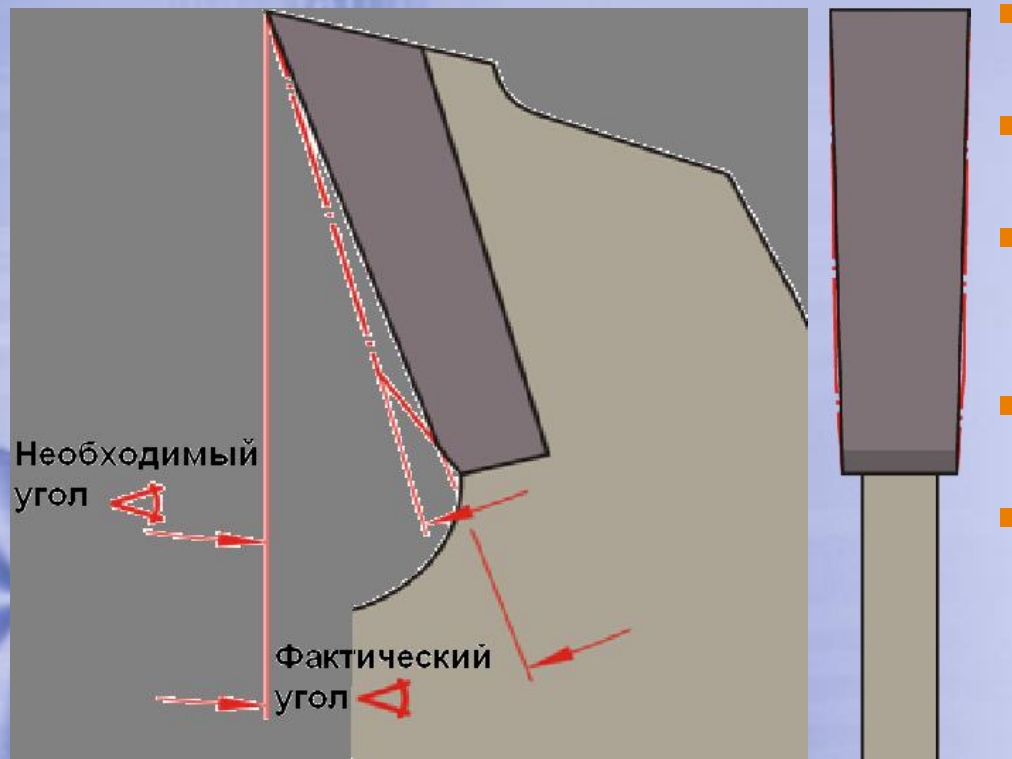



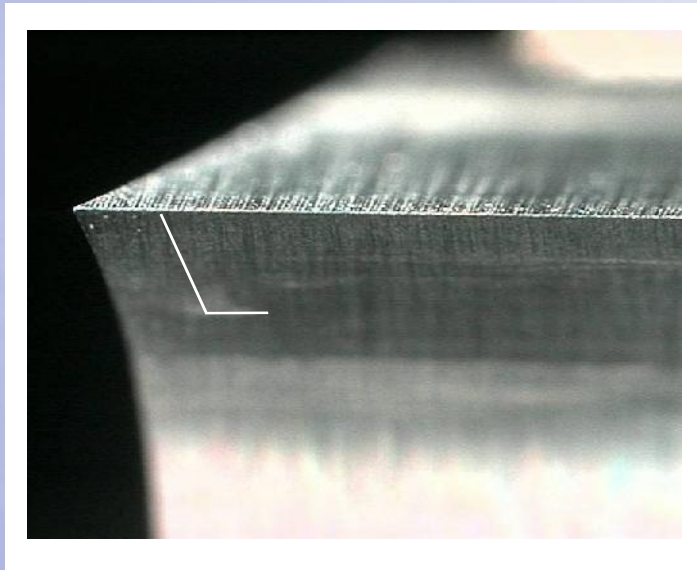
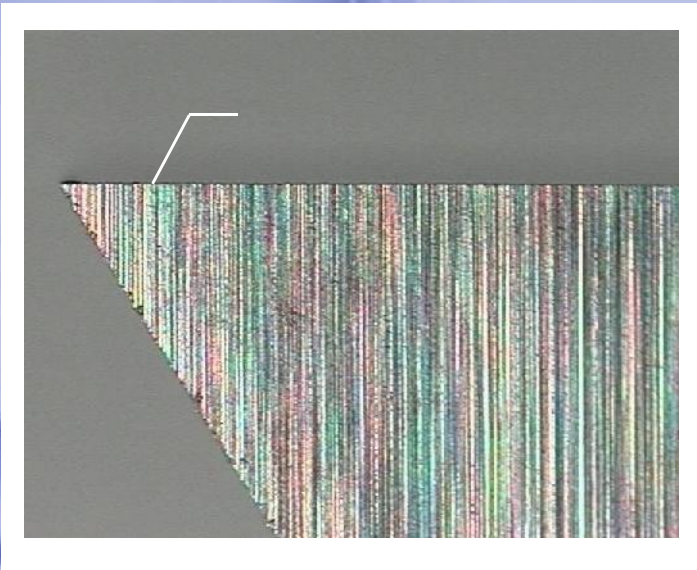

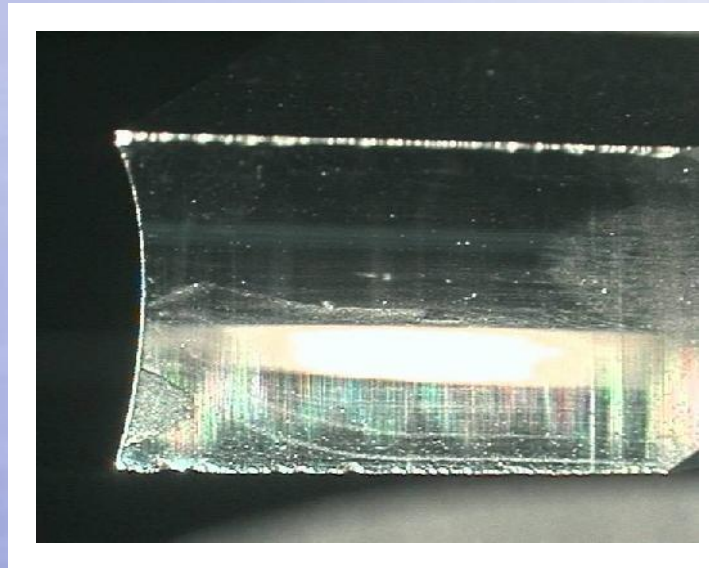
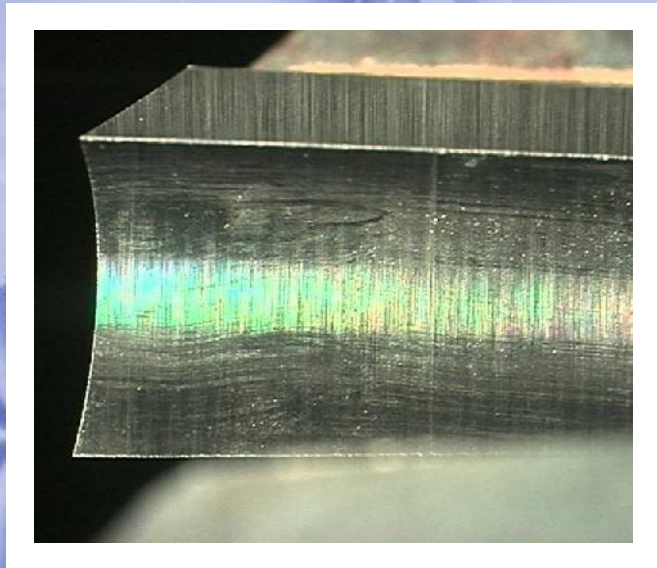

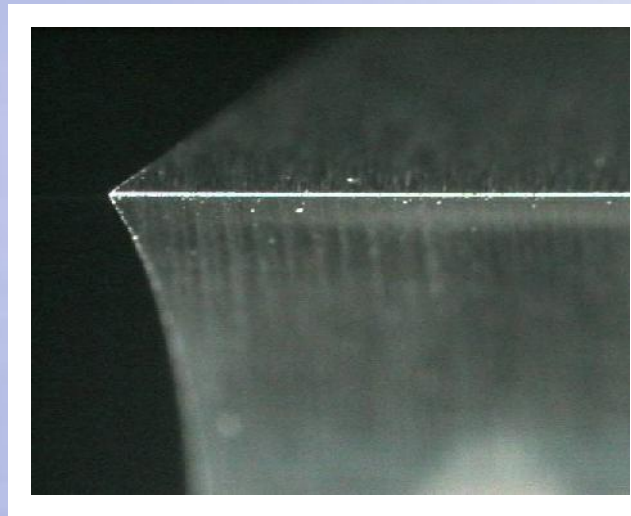
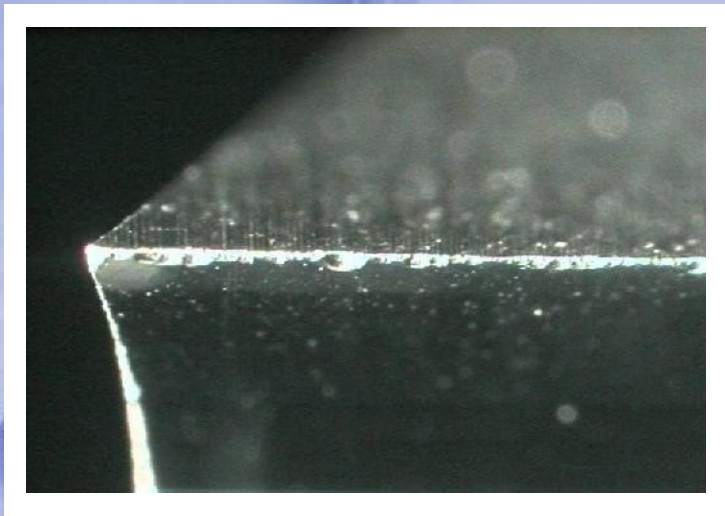

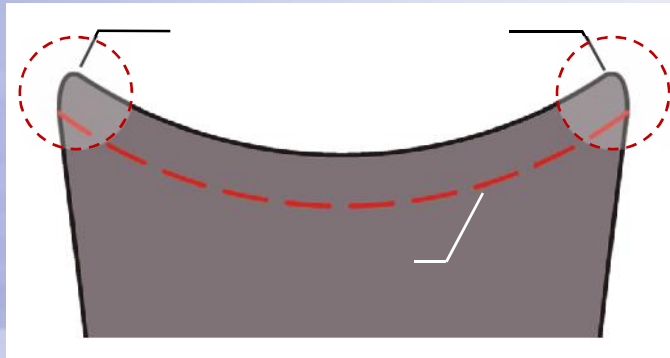

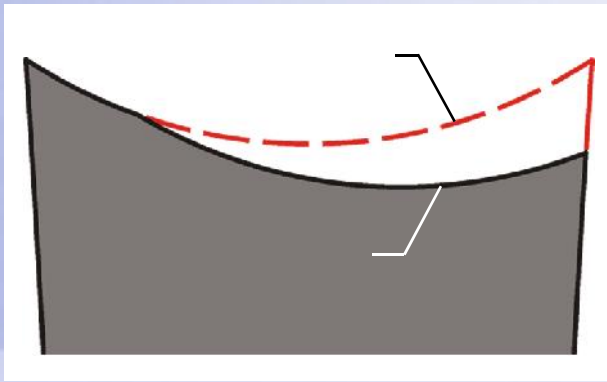
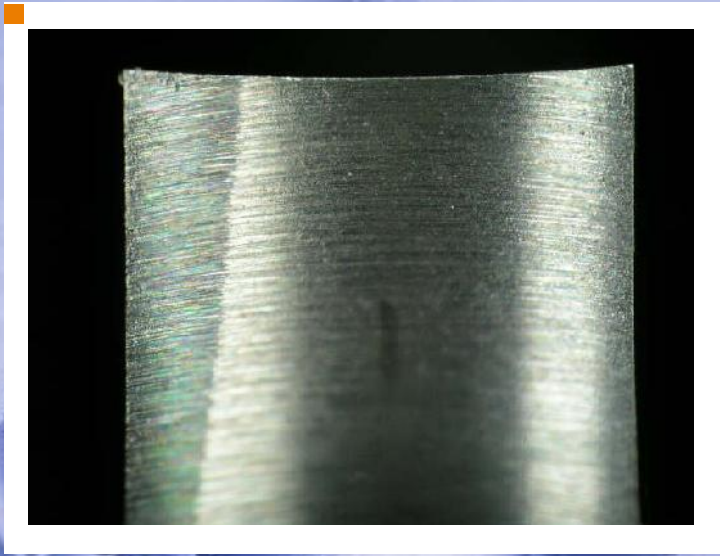

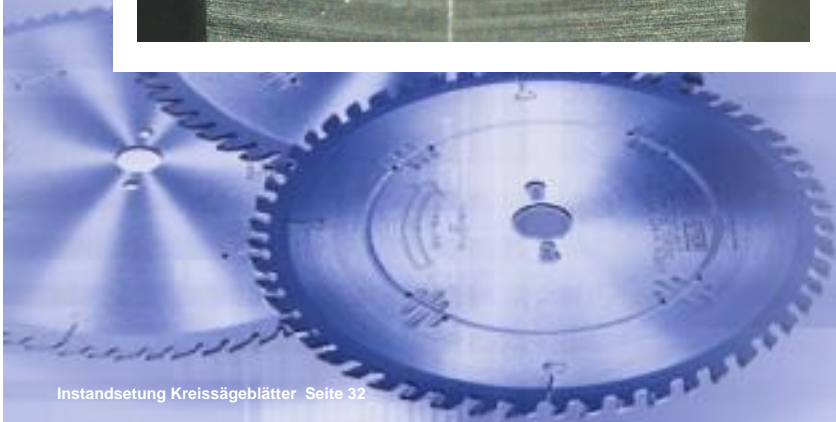
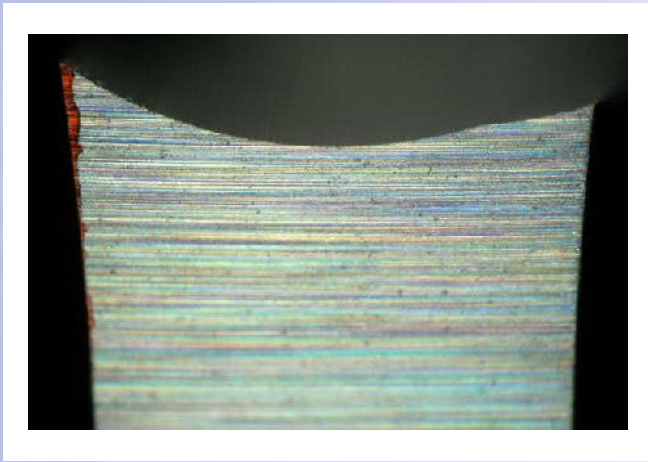
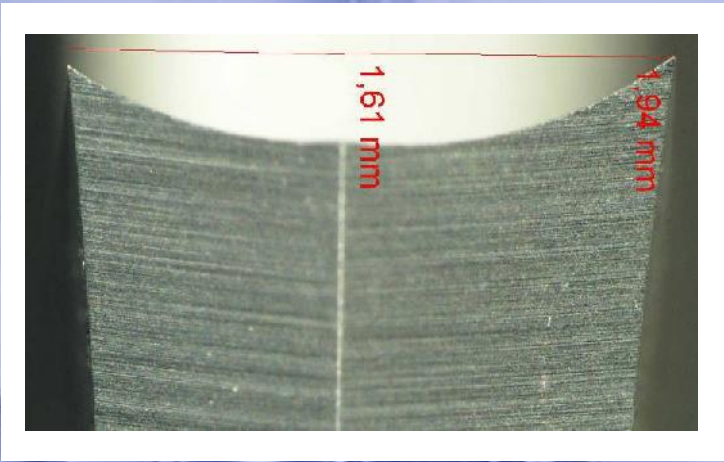

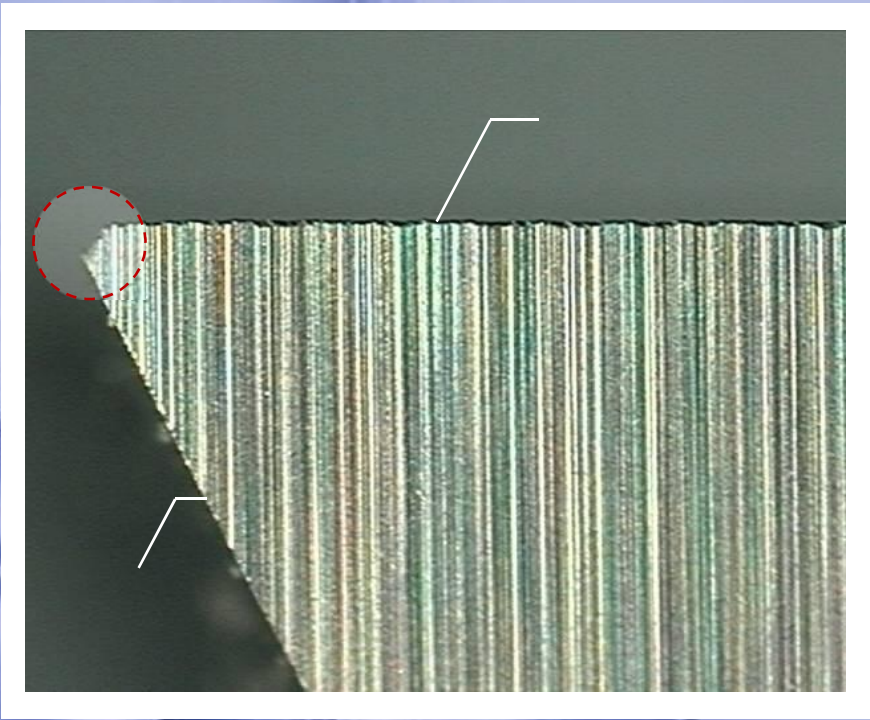

1



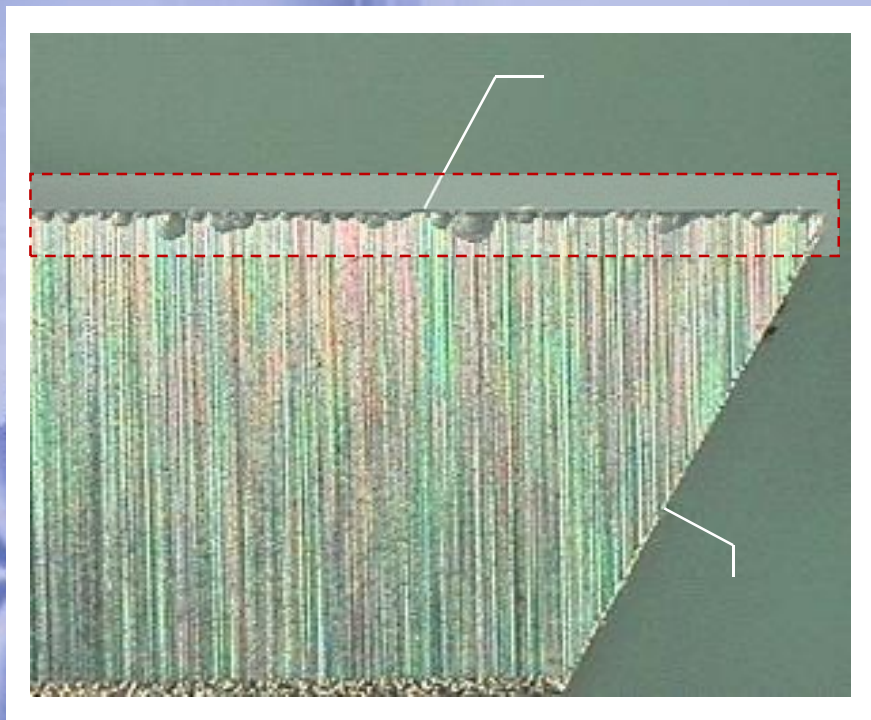

1



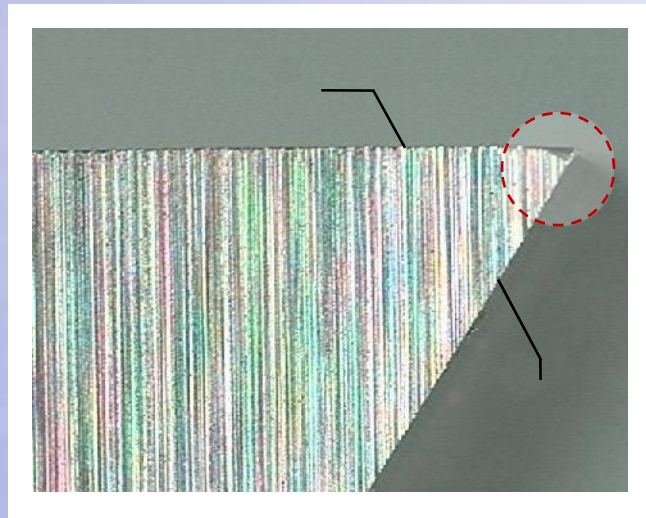
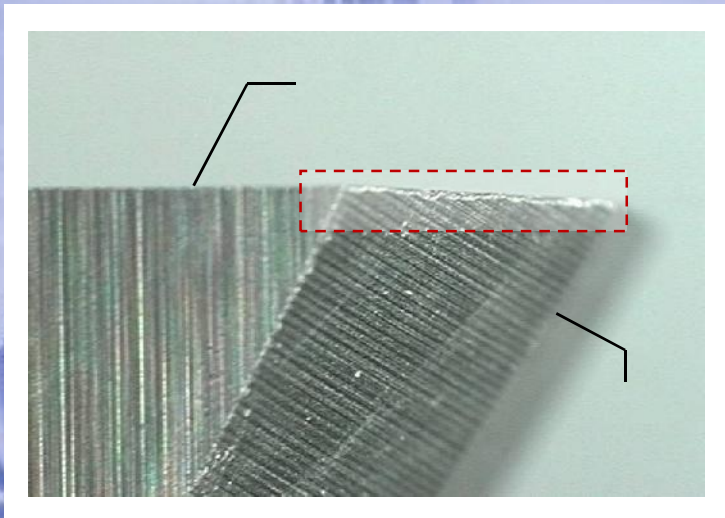

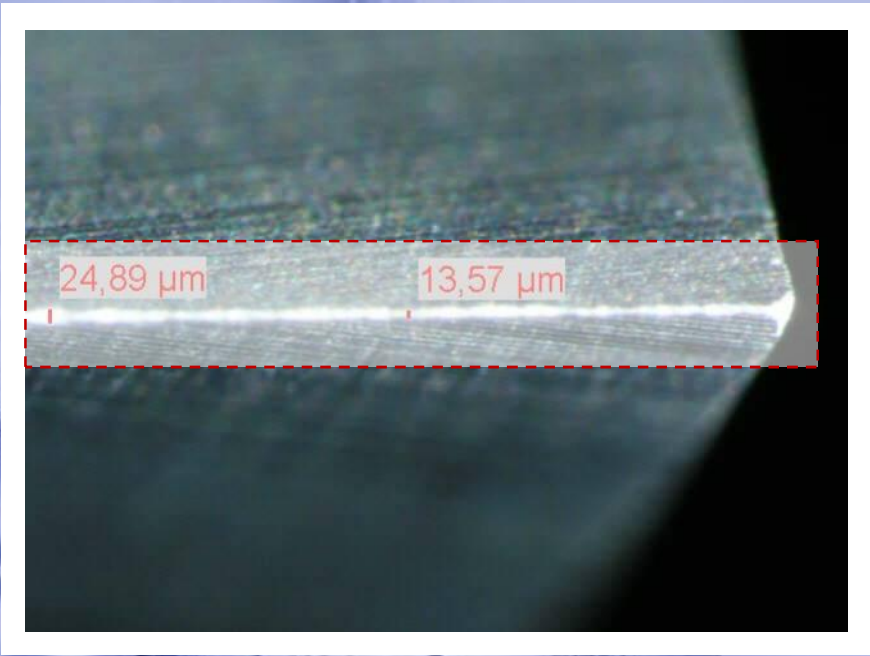

1



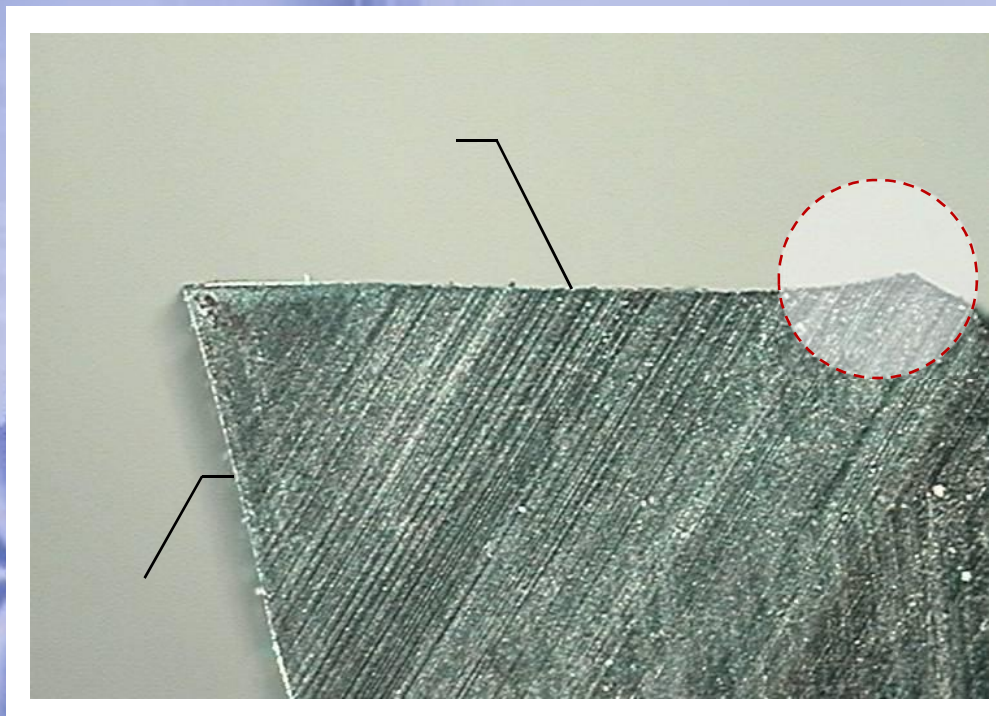

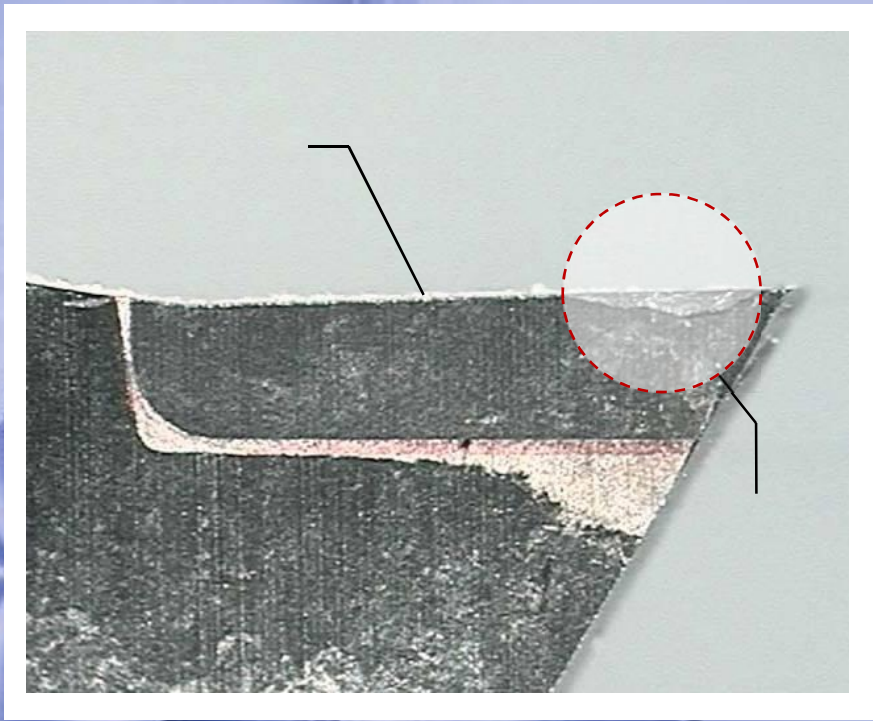

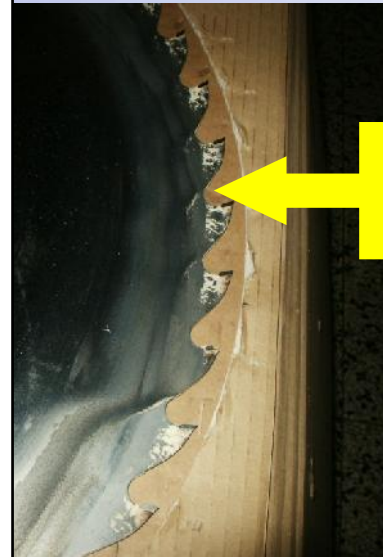
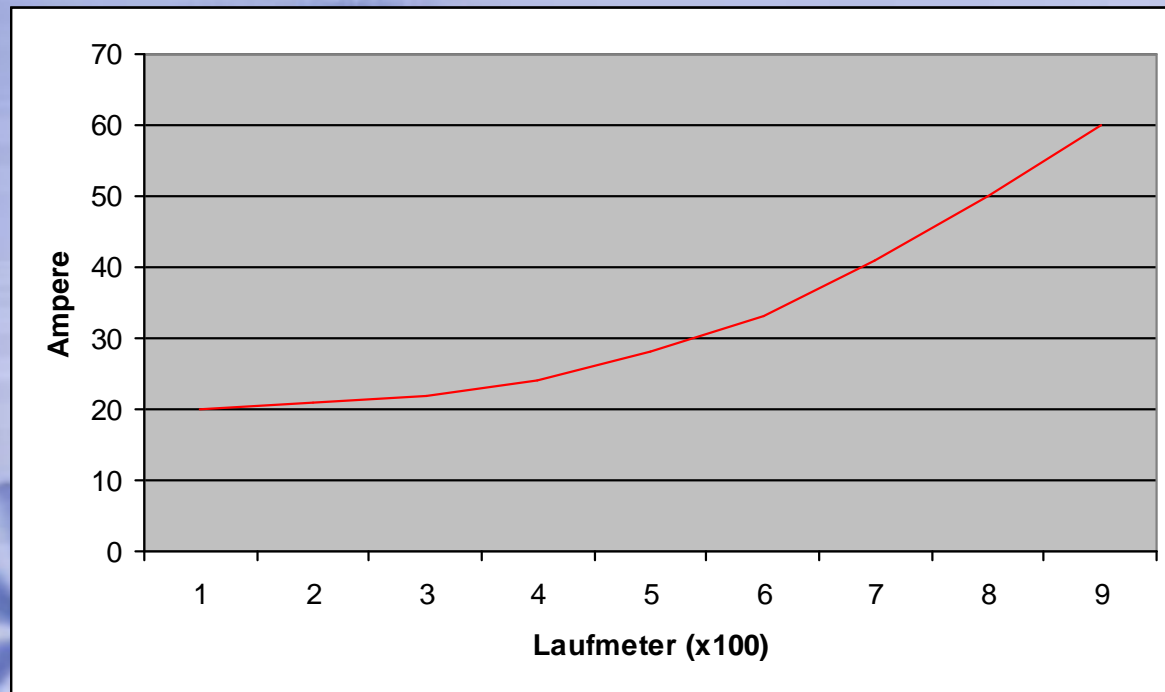

« »

макс. 0,5 мм



неправильно!!!



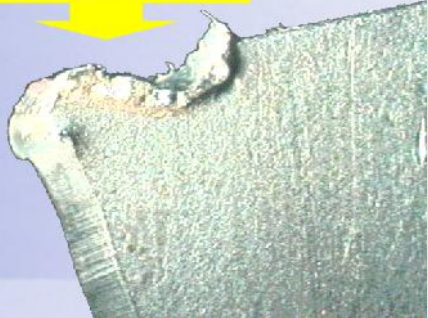

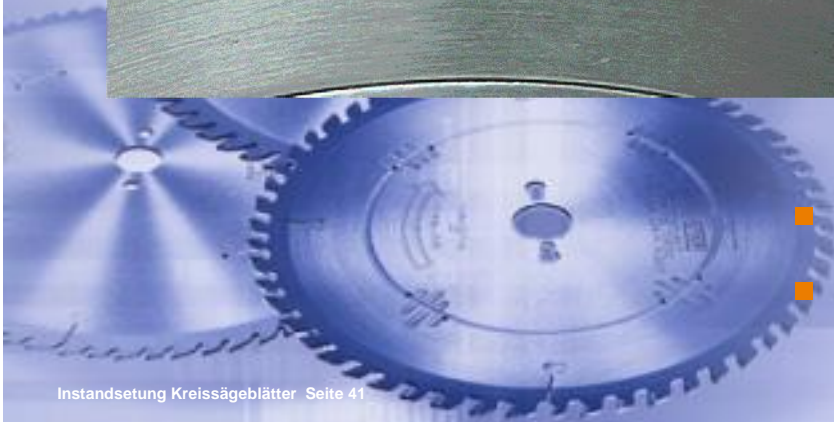
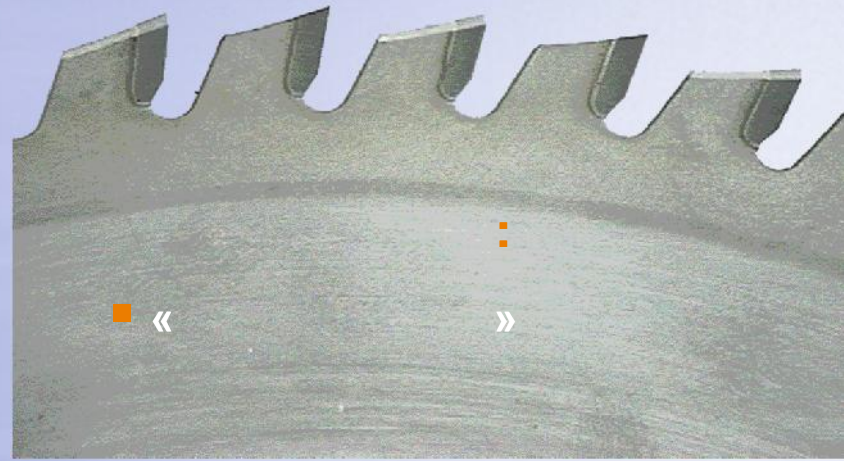
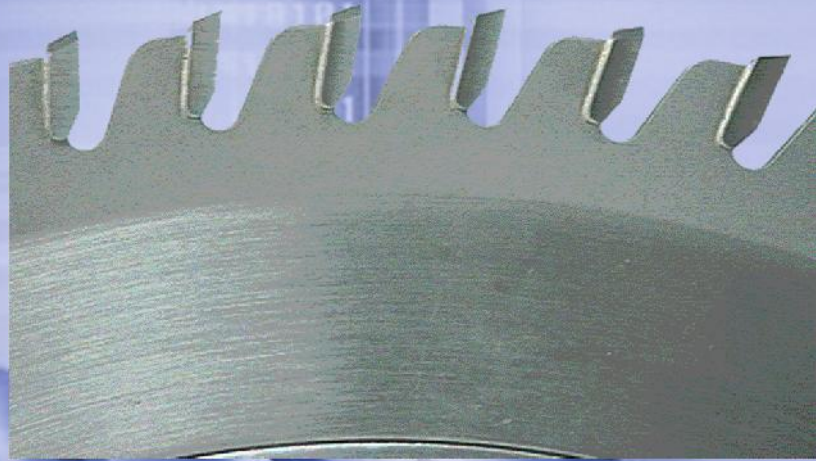

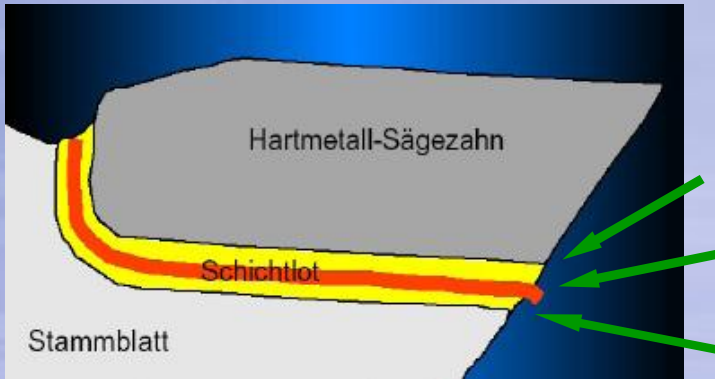

Glühtemperatur Annealing temperature		
°C	°F	
1300	2370	
1200	2190	
1100	2010	
1000	1830	
950	1740	
900	1650	
850	1560	
810	1490	
780	1440	
740	1360	
680	1260	
630	1170	
550	1020	

800° →



750°:

-
-

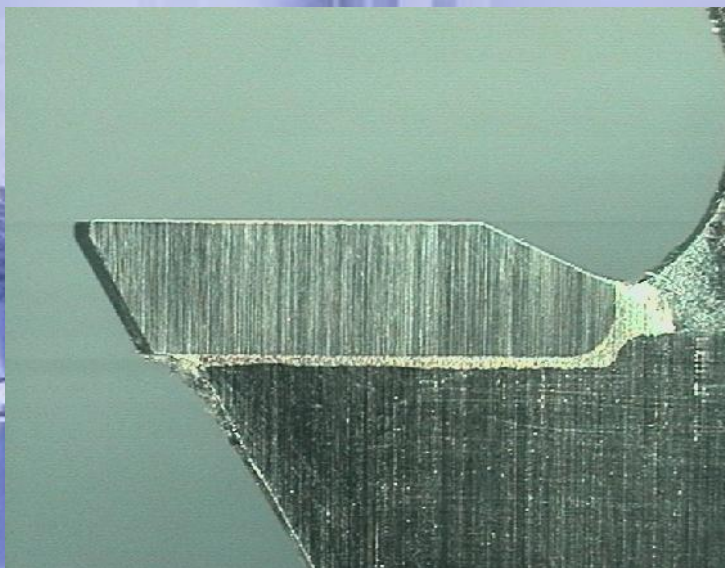

1000°:

-
-
-





!!!



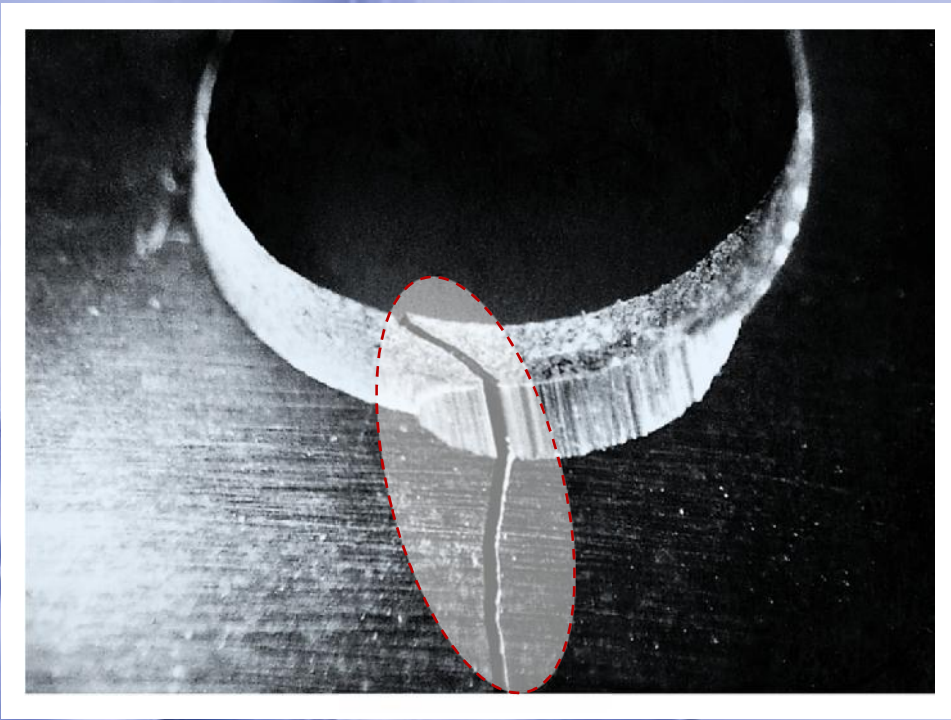

!!!





!!!



LEITZ				
Schärfen	Sägen			
	säge 1	säge 2	säge 3	säge 4
N	6543	2790	1862	2212
1	5155	3089	18	3256
2	129	2301	89	68
3	1667	22	607	3216
4	596	2530	1363	1550
5	27	42	218	1154
6	1196	19	2171	1562
7	1919	200	2800	33,6

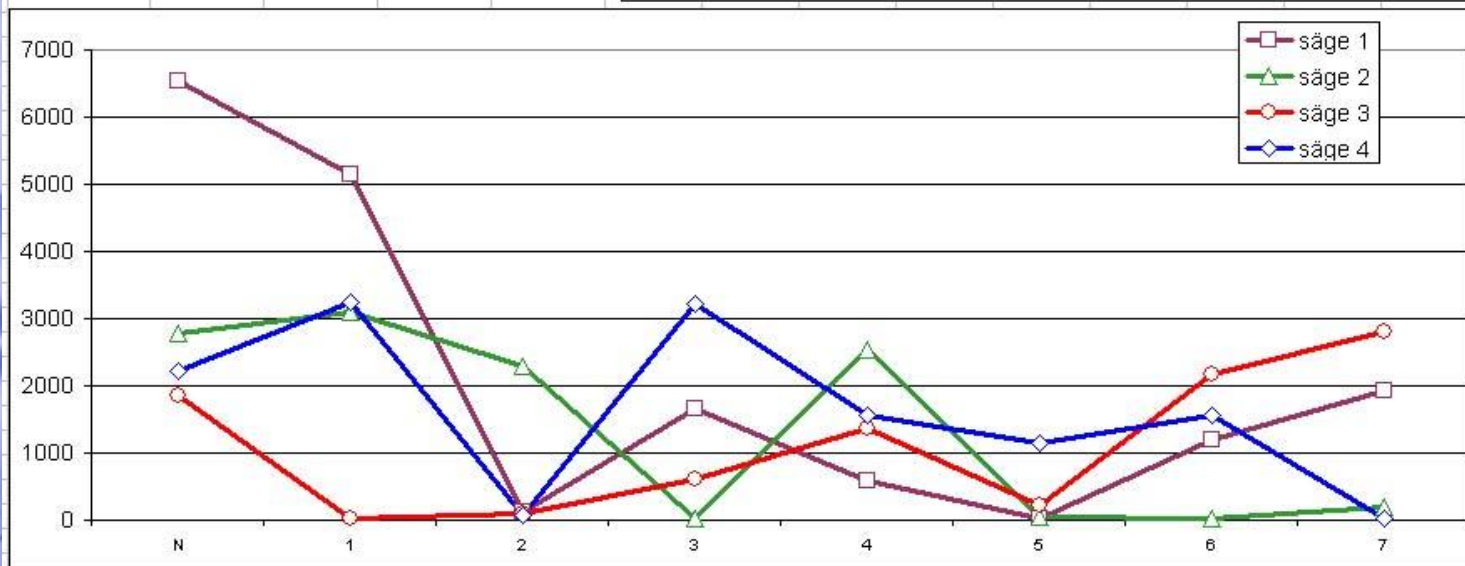
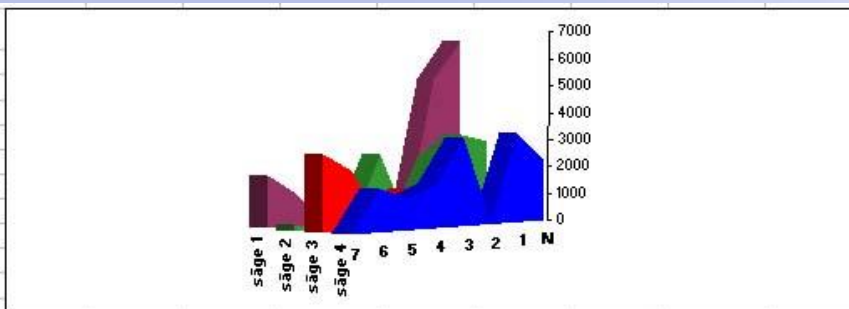

-
-
-

!

Leitz

!

